

**The secret
behind the design
of your Volvo.**

Volvo240/260

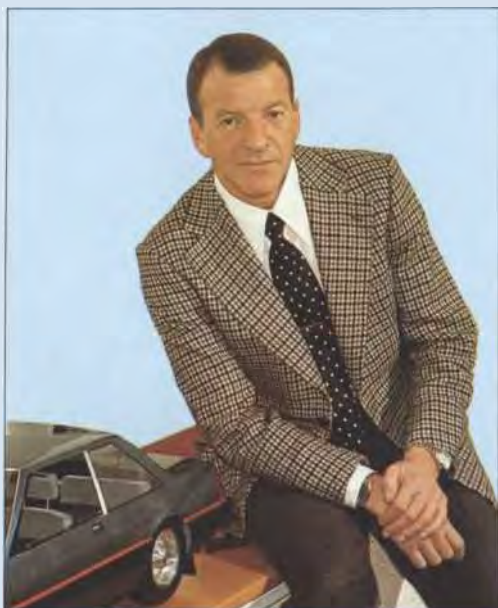

A unique car.

A Volvo car has the longest life expectancy of all car makes and a unique record for safety. That is what this booklet is all about.

I hope you will find it interesting to read and that it will help you to really get to know more about Volvo cars.

P.G. Gyllenhammar
President
AB VOLVO



An extensive test programme makes every Volvo safer to drive.

Operational safety depends on a car reacting in the same way in a crisis as it does in normal driving. And not developing unexpected characteristics that take the driver by surprise.

Many of today's cars, especially those with extreme cornering powers or too much oversteer that reacts too quickly, are liable to do just that.

These are the views of Friedrich Jaksch, head of Volvo's Vehicle Dynamics Department. Jaksch and his colleagues are the people behind Volvo's extensive driving safety research programme.

Most drivers only know how their cars behave in normal everyday traffic. Very few drivers are trained to deal with panic situations. Therefore, most drivers will use their everyday driving routine even in unusual situations.

The Jaksch research programme has played an important part in developing a design that makes a Volvo retain its normal way of responding even in the most difficult situations.





The result is a car that is a true pleasure to drive: a car that you can trust.

This is of course a running research programme. Jaksch and his team are constantly trying to refine the complex interaction necessary between the different features of the car: Roadholding, steering characteristics, engine performance and brake performance, to name a few.

At Hällered for example, Volvo's 1800-acre test area, the team can use all sorts of testing circuits.

In some of the test cars, electronic recording gear records the performance of both car and driver throughout certain specified manoeuvres. The tape are later interpreted by a computer at Volvo's large technical center which also houses a wide variety of equipment for laboratory tests.

Watching the test cars at Hällered is a very convincing experience.

High-speed lane changing, slalom-driving, brake testing on a slippery surface ...

You can even see a tyre being ripped open at 80 mph by a special knife - with little effect on the Volvo's stability.

- Volvo's are legendary for their unique crash-safety

design. It's perhaps not so well known what safe cars they are to drive. Not only for the very skilled driver but for all normal drivers, who get their experience from normal traffic, says Friedrich Jaksch.

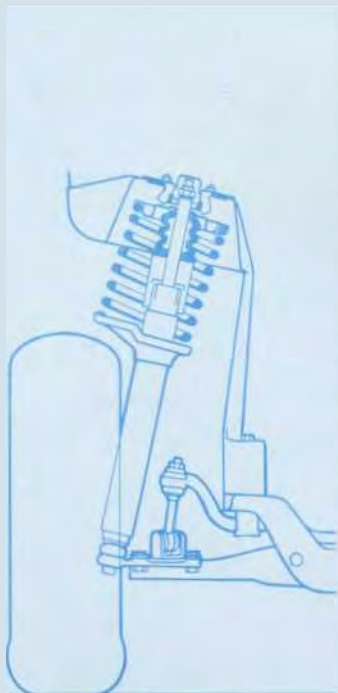

Every Volvo has a dynamic safety design.

The Volvo dynamic safety design helps you to drive safely without any great effort or expert skill under all sorts of conditions. Including extreme situations where other cars might differ from the behaviour the driver has been accustomed to.

The dynamic safety design means that every detail in a Volvo car is carefully calculated to work in perfect harmony with the others. And the driver. To give predictable, stable behaviour.

Here are some examples:

Accurate, quick steering response.

The short delay between steering wheel movement and vehicle reaction is matched to the reactions of the normal driver.

Perfect weight distribution.

A 55/45 weight distribution front/rear is vital to directional stability and safe high-speed cornering. If you for instance go into a bend too fast with a 60/40 or 70/30 weight distribution, the front of your car will slide and the steering become useless. Should you then brake while cornering, the lightly loaded rear wheels will lose grip and the tail of the car will slide out.

A live rear axle.

This is to keep the wheels at a constant angle on the road for predictable and stable behaviour in various situations.

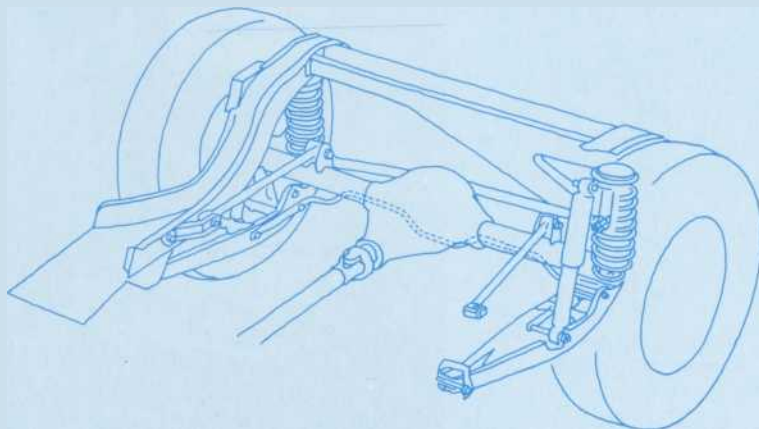

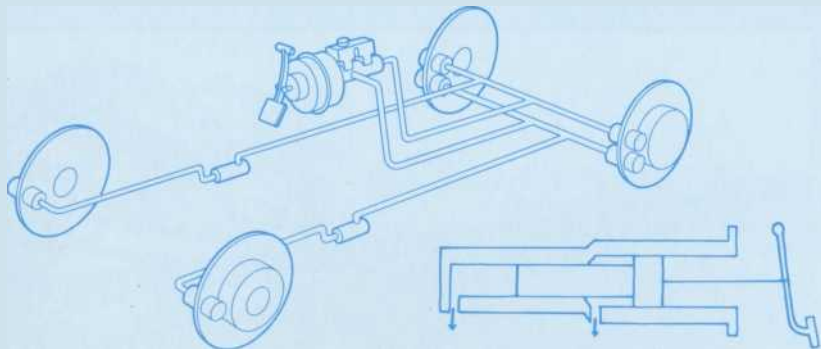

An extremely reliable braking system.

The dual-circuit triangle-split Volvo brakes are next to 100% safe. But should one circuit fail, the system will still provide about 80% of full braking power. And thanks to the unique stepped bore master cylinder you won't need the extra pedal load or notice any extra pedal travel, which makes other cars impossible to stop with only one circuit working.

Concern for your safety is an old Volvo tradition. The laminated windscreen for example was introduced on the PV 444 as early as in 1944. Years before legislation. Safety belts were another early Volvo standard feature. And the Volvo 120 Series introduced the collapsible steering column. Both these models were of course quite sensational cars to drive and won many competitions.





Volvo sets norms for American Safety Research.

The U.S. Government has bought 24 Volkos. After comprehensive tests of all cars on the market, the American National Safety Highway Traffic Safety Administration found the Volvo 244 to be the car that gives by far the best protection to driver and passengers. Based on these findings, the NHTSA decided to use Volkos as a basis for the development of future American safety standards. Volvo is still ahead.

Volvo "The Most Crashworthy Vehicle".

The NHTSA began its research by calculating the potential safety of 21 of the most common sedans in the 2,500 - 3,000 pounds weight class. Five makes went on to further crash-tests against fixed barriers at 45 mph - roughly the equivalent of a head-on collision between two similar-sized cars with a closing speed of 90 mph.

After the crash-tests, computer analyses were made to determine the potential for occupant survival. The results proved Volvo's protection to be far better than its nearest competitor's. In fact, the NHTSA nominated Volvo "The Most Crash-worthy Vehicle.



This is how carefully a Volvo is designed and assembled. In order to achieve the longest life expectancy of all car makes.



- When we design a car we always aim for the best possible quality - expressed for instance in high life expectancy figures and very good reliability, says Håkan Frisinger of Volvo's Car Division.

Today, Volvo has the longest life expectancy - 17.9 years! (According to the statistics of the Swedish Motor Vehicle Inspection Authority).

Our demand for high quality explains why the development and manufacture of a Volvo is such a long process.

- The design and production of the Volvo 240 and 260 Series can be summed up in seven steps. It's our care behind each of these steps that decides the quality of the final product.

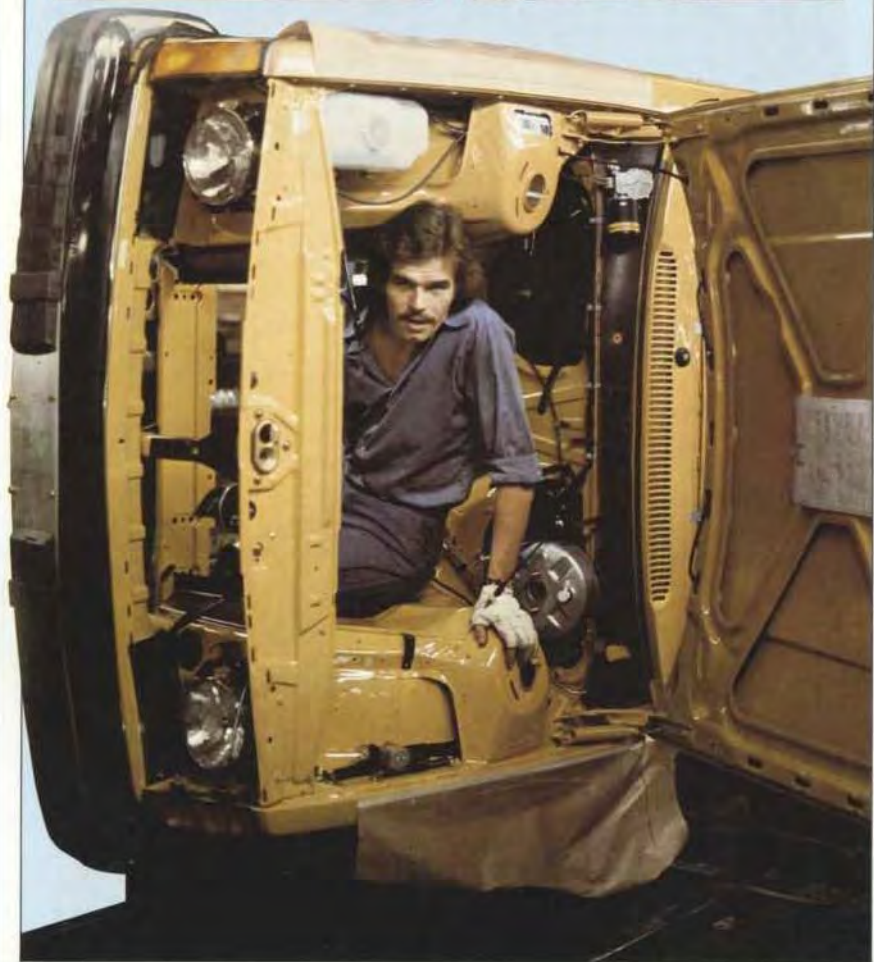
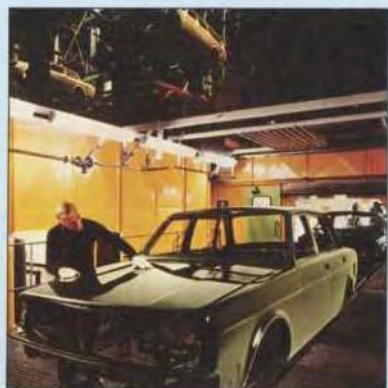



We must test and test again.

This is how Håkan Frisinger describes the seven steps:

We begin with product planning where we decide, in a broader sense, what this car should achieve. How long should it be able to run before any main problems appear? What must we demand of the engine, if the car works that long, etc.

2 Design work begins. The wider goals for the car are split up into separate demands on each component. The final stages here are the prototypes.





3 Time to test the first cars. A very important stage in the process. The cars are tested in our own laboratories and on our test tracks. Also, of course, in all sorts of climates. From the deserts of Australia, to the extremely tough conditions at the Polar Circle. All results are then taken into account by the designers for further development of the car. We then move to new tests, back to design, to new tests, etc., till we finally reach the car we aimed for.

4 Step four involves production preparations. Our production engineers check every detail of the car to determine which production process each component needs. This is also the stage where we try to find out where production could go wrong and correct errors before production actually starts.

5 Quality control, which means a steady check-up during production to see that everything is done correctly.

6 Time for "audit". A group of highly qualified engineers, reporting directly to the President of the Car Division, check five percent of all Volvos to make sure that the manufactured cars meet the quality goals.

7 Customer reactions are fed back into the process, thus helping us to make better cars.

- I might also add, says Håkan Frisinger, that controls and check-ups naturally include the companies manufacturing Volvo components. We also maintain a running check on all our company cars.

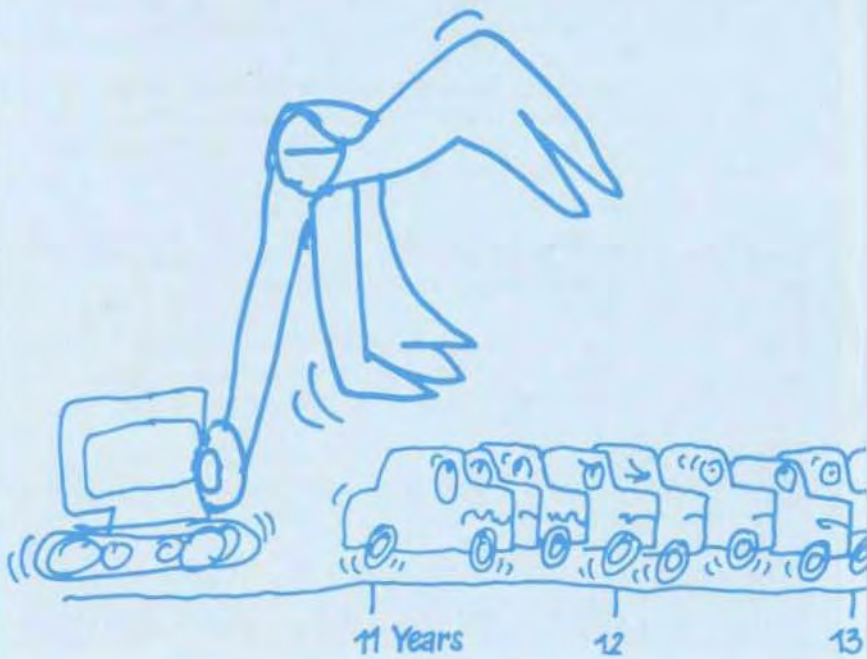



The people who make our cars are our best quality guarantee.

- In the end, says Håkan Frisinger, quality depends on the people who make the car. Take for instance the assembly line. We are trying to create more independent jobs there than you usually find in the car industry. These jobs are more interesting, of course, but also more demanding when it comes to skill, responsibility and care.

Finally every car ends up in the scrap yard. Quality cars get there later, because quality lengthens the life of the car. And, according to official Swedish statistics, a Volvo has the longest life expectancy of all car makes - 17.9 years. This could be described as the point when 50% of the cars are still running. Which is about 3,5 years longer than the average for all makes.

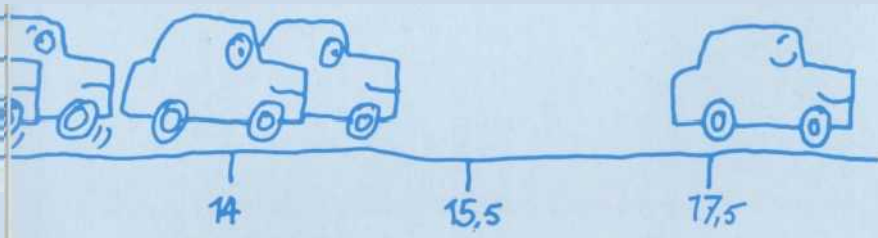

Use all the Volvo comfort features. For safer driving.

Comfort, the Volvo way, is very much a matter of safety. A relaxed, comfortable driver is a safer driver. That is the basic philosophy of Sven Bengtsson, head of Volvo's Interior Design Department and responsible for among other things the design of the seats in your Volvo.

Comfort naturally involves more than sitting. It's question of the entire car and traffic environment. But let's look at the driver's seat as an example of Volvo comfort.

- The Volvo driver's seat is the result of a very careful development programme, says Sven Bengtsson. - We began by stating our objectives. To name a few, the seat must be comfortable to sit in, it should eliminate driving fatigue during long journeys, it must be easy to get in and out of, it should keep the driver safely in place while concerning, and it mustn't be too hot or too cold.



Testing in a road simulator.

To develop these qualities, the Volvo engineers started to work in a simulator - machine where the shaking, bumping, and other movements of a car ride on an actual road have been recorded. - Then our designers decide on the shape, after which we actually made a seat which of course had to be tested again, to fill the norms we had set for it.

As usual the Volvo designers went far beyond legal requirements and it was therefore a long and painstaking procedure indeed to arrive at the final result: the Volvo seat.

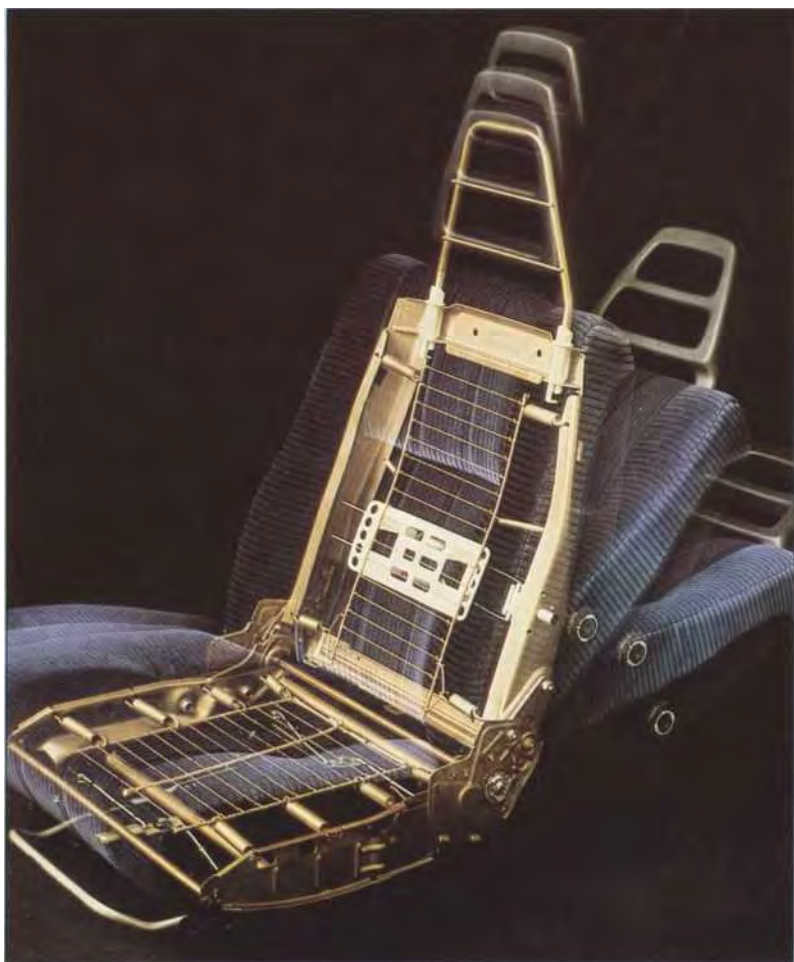

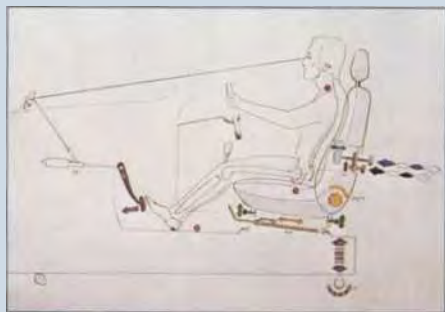

Medical experts have tested the Volvo seat.

This was done by a highly qualified team of doctors at the Sahlgrenska University Hospital in Gothenburg, Sweden. To really make sure that the Volvo seat gives most drivers the driving position necessary for relaxed, and thereby safer driving.

- So today, says Sven Bengtsson. we have a seat that has in fact been recommended by doctors for people with back troubles.

The Volvo seat has so many adjustment possibilities that it fits 97% of all adults.

Forwards, backwards, backrest recline, lumbar support ... even the height of your seat can be adjusted to fit you perfectly. -Just set the seat to the position which is most comfortable, says Sven Bengtsson.

This of course goes for the passenger seat as well. The back seat on the other hand is more difficult to make as adjustable. But it's, of course, designed according to the results of our medical research - firmly padded for long lasting comfort with the right degree of contour to keep three people seated in comfort.



Securely anchored to the floor - for safety's sake - the Volvo seat incorporates a unique number of adjustment possibilities. The backrest is infinitely variable down to a reclining position.

The adjustable lumbar support provides extra pressure to the small of the back. And the seat doesn't only slide forwards and backwards. It can be raised or lowered to nine different positions.

The driving seat is even electrically heated. If the temperature is below 12°C , the seat is automatically heated to 28°C when the key is turned.

The work of the medical teams on the Volvo seat was presented in an extensive scientific treatise.

We take care.

Selling a car does not end with delivery. That is why we consider it our responsibility to make sure that the customer is always pleased with his Volvo. And to help him solve any problems that he might have.

