

THE VOLVO FACT SHEET

A VOLVO GIVES YOU A GOOD RUN FOR YOUR MONEY



When you spend £2,000 odd on a car, you're entitled to know what you're getting and how much of it you can look forward to getting back.

Buying a Volvo is an investment. It's been built carefully and slowly to give you years of trouble-free driving, few repairs and little servicing.

Independent surveys show just how outstandingly reliable the Volvo is. In one survey the Volvo headed the lists for fewest major faults and least loss of use. In fact, the Volvo averaged only one day off the road over a 12 month period.

No wonder in a subsequent survey over 90% of Volvo owners said they would choose one again.

This Fact-kit sets out some good reasons why it's worth your while to buy a Volvo. But you really have to own a Volvo for a number of years to see how much money it will save you.

THE VOLVO FACT SHEET

BRAKING

There are five basic braking systems to be found in cars on the British roads. Look at the diagrams below and compare your car with the Volvo.

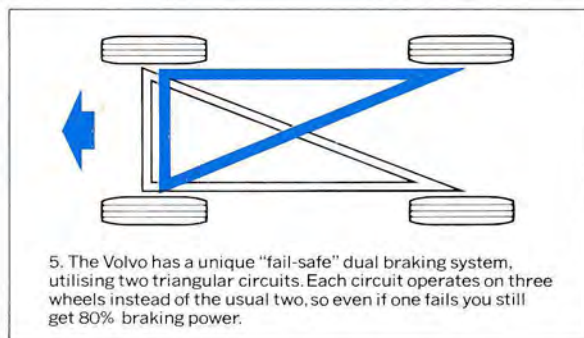
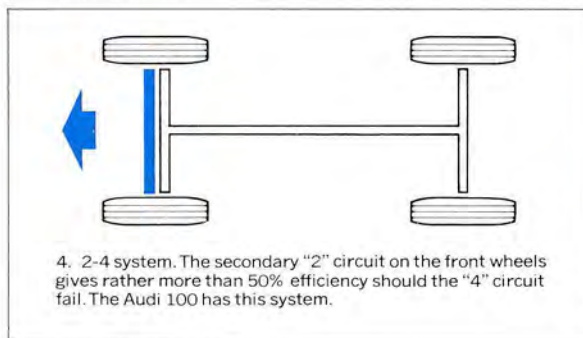
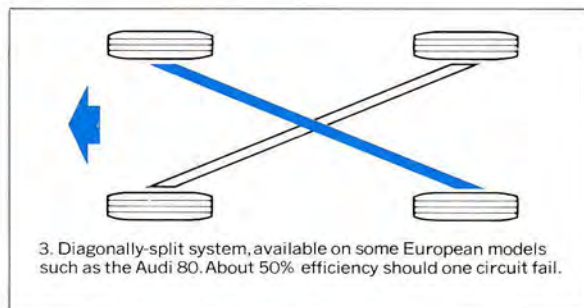
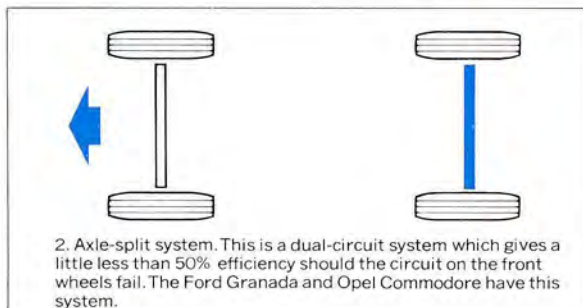
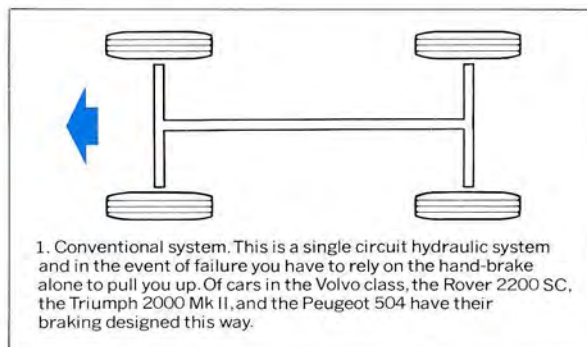

From the diagrams above, you can see that the Volvo gives you better braking protection than any other car in its class.

...

THE VOLVO GIVES YOU BETTER BRAKING.

THE VOLVO FACT SHEET

DEPRECIATION

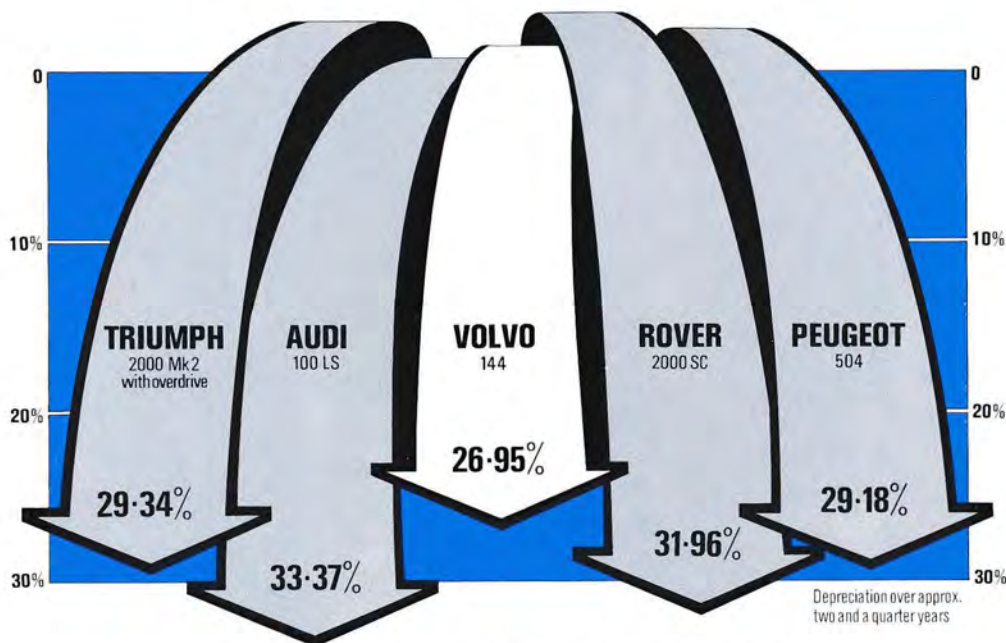

Most cars are built fast—and they fall apart fast.

A Volvo is built very, very slowly. It takes nine hours just to get through final assembly. And it's checked very thoroughly because the more we check it the less you have to.

That's why it gives you so little trouble in repair bills and servicing. And when you come to sell your Volvo you'll find it'll still be worth a lot to you.

Take a look at the table above which compares the Volvo 144 with four of its competitors. The table is based on the costs of each car in December 1971 and the trade guide recommended retail price for February 1974.

Source: Based on information taken from Glass's Guide; the recognised trade guide to car prices.

...

A VOLVO DEPRECIATES AS SLOWLY AS IT GROWS OLD

THE VOLVO FACT SHEET

LIFE EXPECTANCY

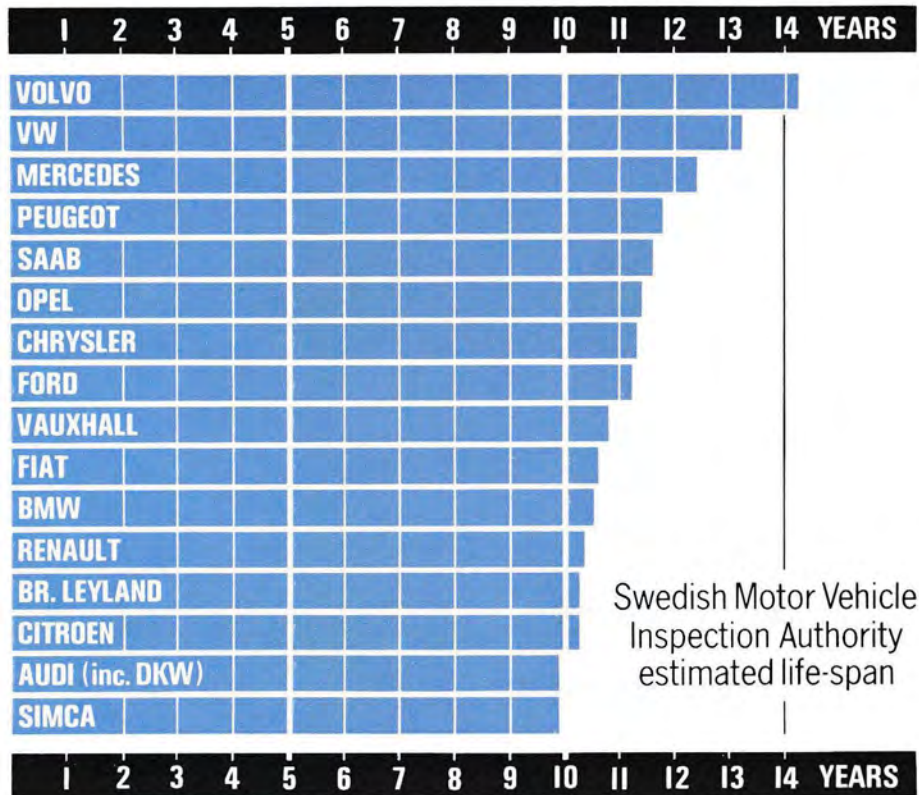

The Swedish Motor Vehicle Inspection Authority produces a table of the average expected life-span of cars available in Sweden on a national basis every year.

Volvo has headed the list every year since the scheme was introduced. You can see how much longer a Volvo lives by the table above.

...

VOLVO-COULD YOUR CAR LIVE SO LONG?

THE VOLVO FACT SHEET

OVERALL PETROL CONSUMPTION

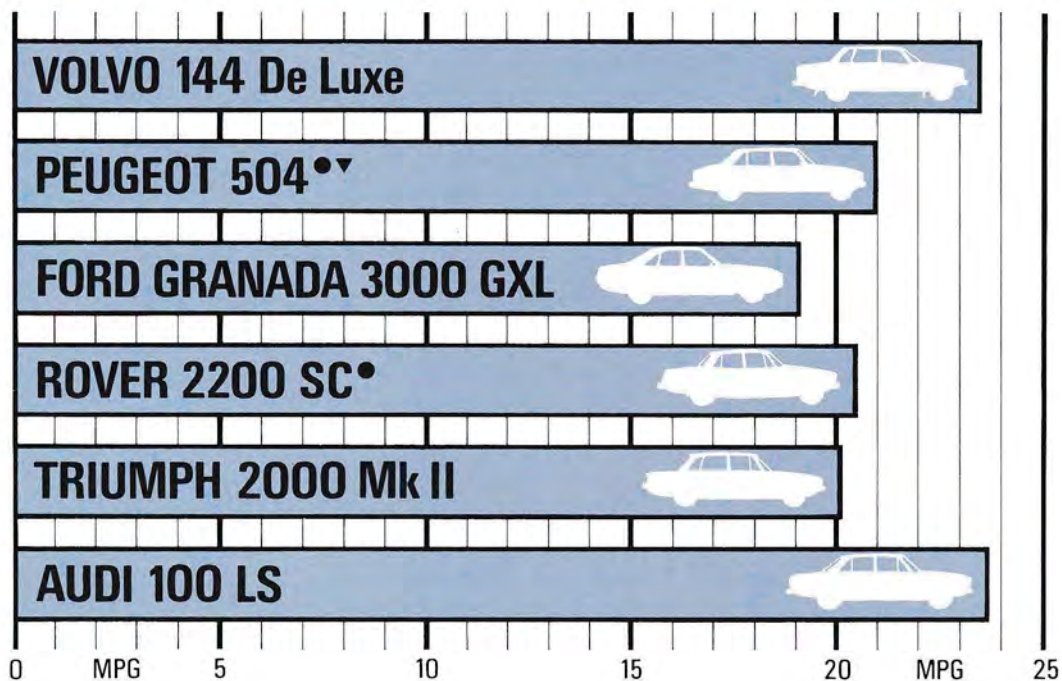

As you can see from the table above, the Volvo 144 De Luxe runs true to form on petrol economy. It's worth remembering, too, that the fuel injection version of the same car, the 144E, gives you much the same figure on two star petrol.

But don't forget economy isn't only how many miles to the gallon, it's also how many years to the car.

● Automatic Transmission ▼ Fuel Injection Source: This Fact Sheet is based on information published by Autocar.

...

THE VOLVO GIVES YOU GOOD M.P.G.

THE VOLVO FACT SHEET

PERFORMANCE

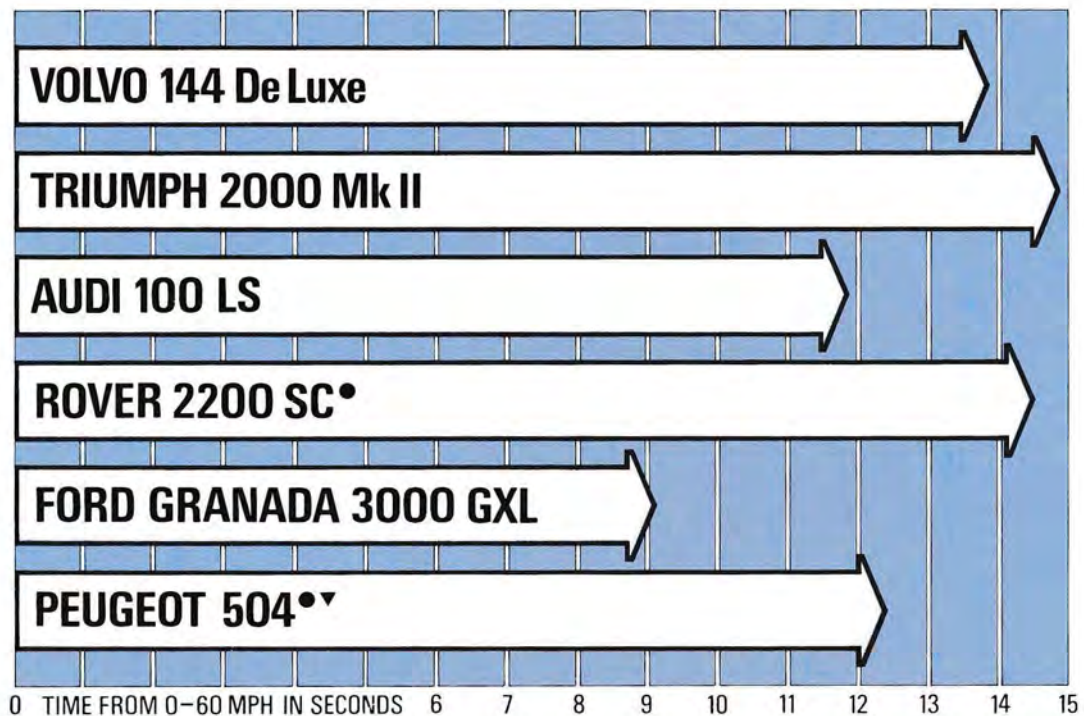

A Volvo is up with cars in its class in terms of performance. It has a four cylinder B.20A engine developing 90h.p. SAE. But where it really scores is with its excellent torque characteristics, giving more pulling power over a large range of engine speeds. This means frequent gearchanging is avoided. You'll also notice your Volvo's exceptional power when towing a heavy load — a caravan, for example.

It's worth remembering that the Volvo engine is sturdy and untemperamental and will keep going strong for a great many years. Ask a man who owns one.

Bear in mind, too, that the fuel injection Volvo 144E gives you a 0-60m.p.h. time of 12.5 seconds.

● Automatic Transmission ▼ Fuel Injection This Fact Sheet is based on information published by Autocar. ...

A VOLVO HAS GREAT PULLING POWER

THE VOLVO FACT SHEET

PROTECTIVE FINISH AND RUST-PROOFING

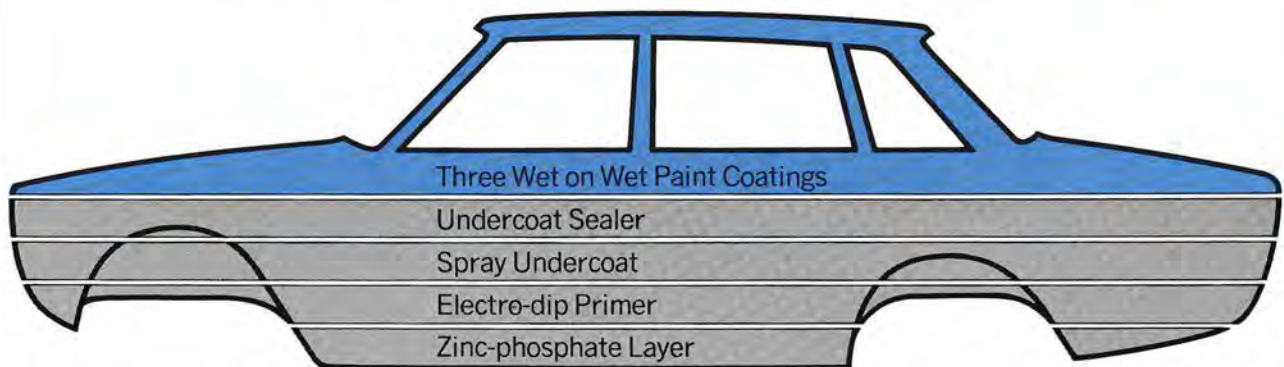

It's worth remembering that the Volvo is built to withstand the ravages of a Swedish winter—with enormous quantities of salt on the road. So it's got to be really well-covered to protect it from the elements.

Protective Finish: The first stage of the painting process is spraying with a zinc-phosphate solution. This increases rust-proofing capabilities, and provides better adhesion for the subsequent layers of paint.

Next the whole car is immersed in a special tank and a thick coat of primer is electrically bonded to the sheet metal, before being baked on for thirty minutes:

Then an undercoat is sprayed on, rubbed down, washed and after three separate quality control inspections coated with a final sealer.

Only then is the car ready to receive its three coats of surface finish. In all 33lbs. of paint are used for every car.

Rust-Proofing: The Volvo's rust-proofing is really thorough. Particularly exposed parts of the body are protected by hot-dip galvanizing. This means that the parts concerned are covered by a thick coating of zinc.

The underbody is treated with a really effective rust-proofing compound. Less exposed parts receive a protective coating of a special rust inhibiting liquid, which forms a tough tenacious skin.

Rust-proofing of the bottom rails—or door sills—is extra effective, since these are cavity ventilated by the slipstream. This means that any moisture that may be present quickly disappears.

...

VOLVO-WE FINISH BETTER

THE VOLVO FACTSHEET

RELIABILITY



Over the years, the Volvo has built up an unchallengeable reputation for reliability. So much so, that it is now widely used by police forces throughout the country, who need a fleet that can perform day in, day out, with the minimum of maintenance. Hampshire police, for example, have 42 Volkvos; and the following comment

by their spokesman, which appeared in the Daily Mail on September 28th, 1973, is typical: "It's very difficult to find a British car which comes up to them." He went on to say that the Volkvos each gave 120,000 miles of good service. They were cheaper to run, and were not in the workshops so often as the rest of their fleet.

No wonder the Volvo mileometer has six digits. Volkvos keep going when other cars have fallen by the wayside.



...

VOLVO'S REPUTATION FOR RELIABILITY IS A MATTER OF FACT.

THE VOLVO FACT SHEET

SAFETY

Manufacturers' built-in safety features	VOLVO 144 de luxe	AUDI 100 LS	FORD Granada 3000 GXL	PEUGEOT 504	ROVER 2200 SC	TRIUMPH 2000 MKII	OPEL Commodore Model 19
Tubular bars in doors for side impact protection							
Heated Rear Window							
Triangle Split Braking System							
Disc brakes on all 4 wheels							
Head Restraints							
Laminated Windscreen							
Completely independent handbrake system with separate drums							
Three-point Safety Belts							
Collapsible Steering Column							
Steering wheel aligns with body on impact							
Steel Cage body							
Front and back impact protection							
Roll over bar							
Safety Belt warning device Audio/Visual							
Exterior light failure warning device							

Volvo started pioneering safety features back in the '40's, long before it was legally necessary to do so. Today, in both the quality of its design and the quantity of such features, the Volvo is acknowledged to be one of the safest cars on the road; and it is part of the Volvo design philosophy to continue to search for even safer motoring.

This information is based on 1974 models.

...

THE VOLVO IS A SAFER CAR

THE VOLVO FACT SHEET

TURNING CIRCLES

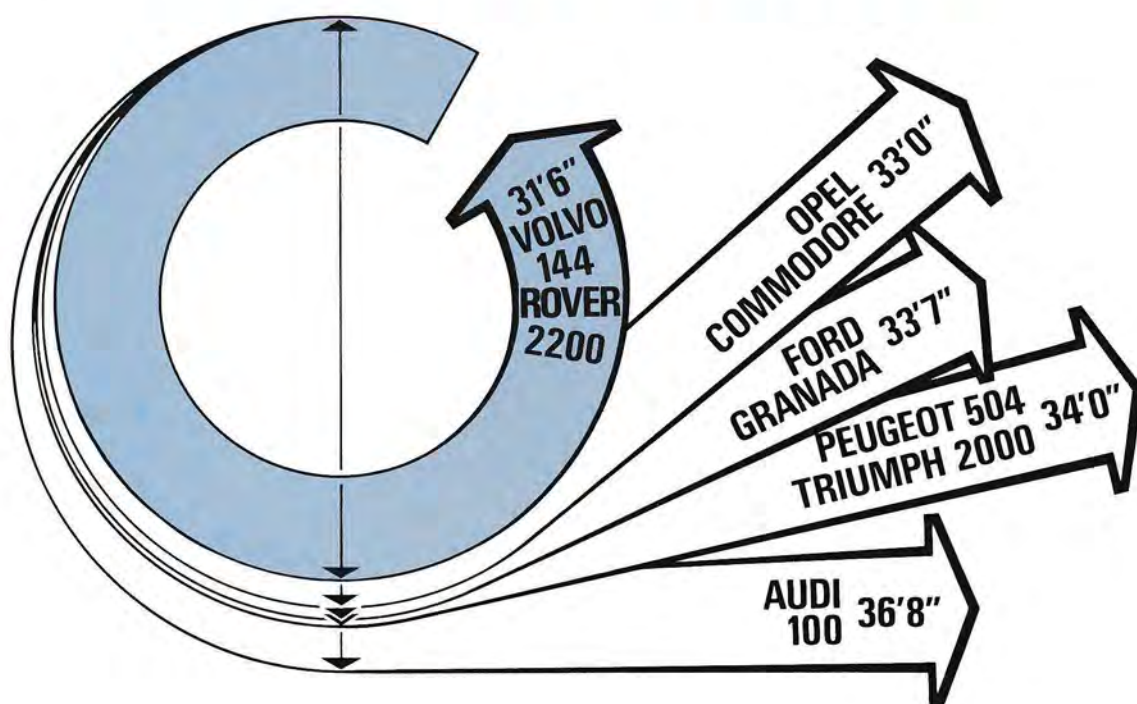

It might surprise you to know that the Volvo has a turning circle not much bigger than a Mini—although the Volvo's nearly half as long again.

Its turning circle is actually smaller than that of a 1200 Beetle, or a Renault 5. Which means that it's more manoeuvrable than a lot of small cars, or just as handy as a Daf or Honda.

Volvo's discreet turning circle is just one of the little things that make it a pleasure to drive.

Source: Manufacturers and Manufacturers 1974 Model Brochures.

...

A VOLVO WILL GET YOU OUT OF THE TIGHTEST CORNERS

THE VOLVO FACT SHEET

WARRANTY

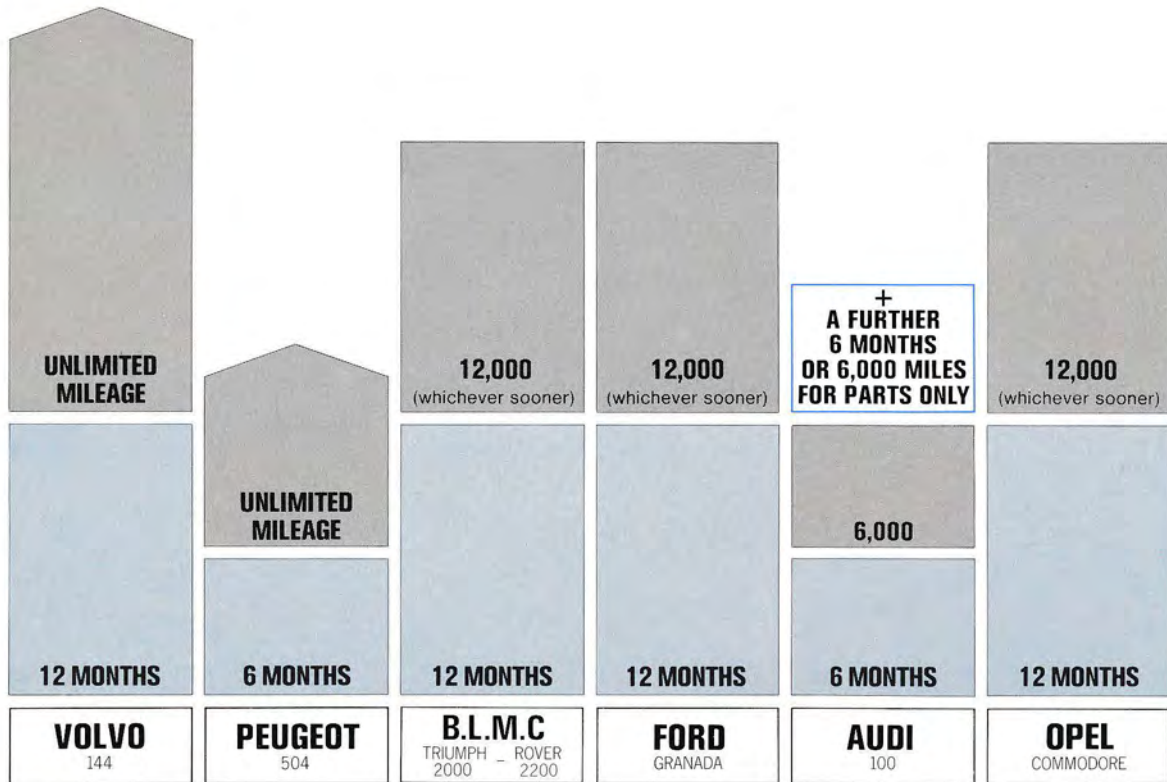

We've got a great deal of confidence in the way we build our cars—and we pass it on to you.

Volvo offer you a much better warranty than their competitors. Here's a comparison.

...

VOLVO-WE CAN AFFORD TO BE GENEROUS

THE VOLVO FACTSHEET

SUMMING UP



We hope we've done a little to convince you of the good investment qualities of the Volvo. As you can see, on such things as reliability, guarantee, depreciation, safety, it brooks no rival. You'll find it's a car that grows on you—the more you drive it, the more you'll appreciate its qualities.

Why not look in at your local Volvo dealer, and get to know the feel of the Volvo as well as the facts?

To the best of our knowledge the information contained in these fact sheets is correct at time of going to press. (May 1974.)

...

IT'S THE LITTLE THINGS THAT MAKE A VOLVO GREAT