

VOLVO

Service Bulletin

Fault Tracing
Repairs
Maintenance



MODEL 200	GROUP 83	NUMBER 202
TITLE SUNROOF WEATHERSTRIP 244 ALL		
MARKET US and Canada		DATE November 1992

Page 1 of 3

REFERENCE: TP 31120/1 (ENGLISH); 12/87; BODY FITTINGS, INTERIOR, HEATING AND A/C

Replacement of sunroof weatherstrip

A new weatherstrip has been developed to help eliminate wind noise from the sunroof. Weatherstrip, p/n 3540456-5, has been added as a replacement part, replacing the earlier type, p/n 1255334-5.

The procedure for installing the new weatherstrip is described below.

Adhesive required: p/n 1161095-3 (250 ml container).

Tools: Cutting pliers, hammer, scraper, adhesive brush

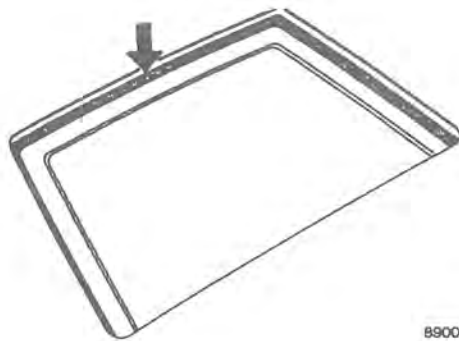

8900001S

Preparations

Body

Open sunroof fully, remove wind deflector and wipe opening clean.

Remove original weatherstrip.

Clean remains of adhesive etc. from contact surfaces.

Service Personnel: circulate, read, and initial.

SERVICE MANAGER	SHOP FOREMAN	SERVICE ADVISOR	SERVICE TECHNICIANS								



Printed in USA on recycled paper containing a minimum of 50% wastepaper and 10% post-consumer waste.

© 1992 VOLVO CARS OF NORTH AMERICA, INC.

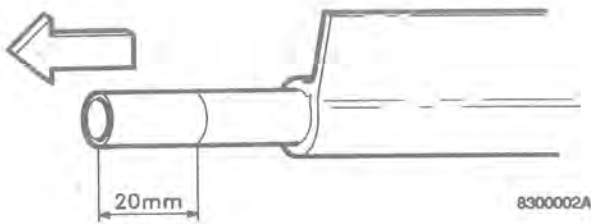

Weatherstrip

Use new weatherstrip, p/n 3540456-5.

Pull out and cut off 20 mm (0.78 in) of silicone core at each end so that each end of strip terminates with approx. 20 mm (0.78 in) of fabric.

Place weatherstrip on table. One side of strip has seam which may be difficult to see. Bend strip in either direction to identify seam.

Apply masking tape according to figure.

Weatherstrip should be bonded on side with seam.



WARNING: Ensure that ventilation is satisfactory when applying adhesive.

Coat weatherstrip twice on shaded area with adhesive to saturate it.

Wait approx. 30 minutes between coats.

Wait 4-8 minutes after second coating prior to applying the seal to the roof opening (until adhesive is no longer sticky).

Remove masking tape.

Apply adhesive to sunroof opening

Apply thin layer of adhesive all around edge of opening.

Note: Too much adhesive will impair adhesion.

Wait 4-8 minutes until adhesive is no longer sticky.

Attach weatherstrip to body with silicone core upmost.

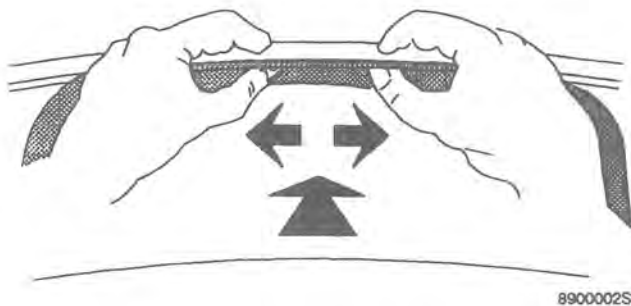

Position weatherstrip as follows:

At front edge: 1-2 mm (.04-.08 in.) below roof panel

At sides: 2-3 mm (.08-.12 in.) below roof panel

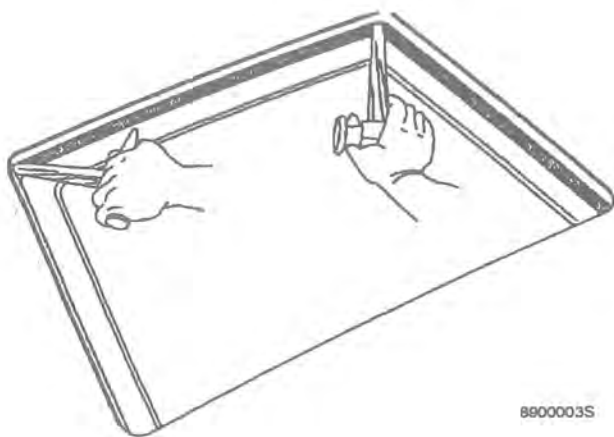

8900003S

Note: It is important to press the weatherstrip into contact with the body **immediately after** installation to ensure firm adhesion all the way around the sunroof.

This may be carried out with the end of a hammer handle.

Close sunroof and test sealing.

Install wind deflector and make sure that side brackets do not come in contact with seal.

WARRANTY STATEMENT: Claims may be submitted during the New Car Limited Warranty using:

Oper. No.	Labor Description	Time Allowance
836322	Sunroof weatherstrip, replace	1.1 hr

